



*An Online CPD Course
brought to you by
CEDengineering.ca*

Fundamentals of Modern Electrical Substations - Part 1

Course No: E02-010
Credit: 2 PDH

Boris Shvartsberg, Ph.D., P.E., P.M.P.



Continuing Education and Development, Inc.

P: (877) 322-5800
info@cedengineering.ca

Introduction

One of the main goals that every electrical utility company has is transportation of electrical energy from the generating station to the customer, while meeting the following main criteria:

- High reliability of power supply
- Low energy cost
- High quality of energy (required voltage level, frequency etc.)

Part 1 of this course series is concentrated on demonstrating how modern power systems are arranged to accomplish all these goals; what place electrical substations have in the overall power system structure; and how important they are for reliable and effective operation of power systems.

Part 1 also provides an overview of substation major equipment, explaining the mission, and arrangement of each component.

To better understand the importance of electrical substations, let's start with a discussion about the structure of the power systems and their main components.

Power System Structure

The typical power system structure is shown in Fig. 1.

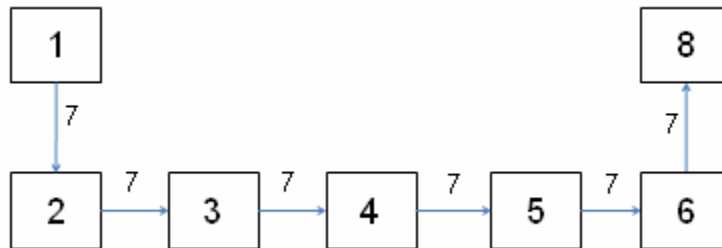

Where:

- 1 = Generator
- 2 = Generating station's step-up transformer substation
- 3 = Extra high voltage step-down transformer substation
- 4 = High voltage step-down transformer substation
- 5 = Distribution substation
- 6 = Distribution Transformer
- 7 = Transmission and Distribution Lines
- 8 = Customer

Fig. 1. Power System Structure and Main Components.

The elements from 2 to 7 are the components of the utility company Transmission and Distribution (T&D) Systems, with typical power system voltages as follows:

- Generation: Up to 25 kV
- Transmission: 115 – 1500 kV
- Subtransmission: 26 – 69 kV
- Distribution: 4 – 13 kV
- Customer: Up to 600 V

Justification for Voltage Transformation

As we can see from Fig.1, along the route from the source to the customer, electricity is undergoing numerous transformations, with generating voltage getting stepped-up to transmission level with a follow-up decrease down to distribution and eventually customer levels. Why do we need to do it? As previously mentioned, the utility company wants to keep energy costs down. One of the ways to do it is to reduce power and energy losses, which may be accomplished by raising the voltage level, because power losses ΔP have a functional relationship with voltage level described in the following equation:

$$\Delta P = F (S^2 \times L / V^2) \quad (1)$$

Where:

- S = transported apparent power
- L = distance to the customer
- V = system voltage level

As we can see, there is a reverse proportion between power losses and voltage level in the 2nd degree. For example, if we increase voltage 10 times, power losses will be 100 times smaller.

Another benefit from raising the voltage is a reduction of voltage drop, which is related to voltage level ΔV as follows:

$$\Delta V = F (S \times L / V) \quad (2)$$

Having a smaller voltage drop in the system helps the utility company to meet its other objective – to provide the customer with a high quality electrical energy meeting specific voltage level requirements.

That's why we increase voltage for transmission of electrical energy, but after it is delivered to the area where customers are located, we gradually lower the voltage to the safe utilization level (208/120 V, for example). Obviously, electrical transformer substations are playing a major role in accomplishing this task. The number of steps in

raising and lowering the voltage is being defined through optimization studies performed by utility company planners.

Mission of Substations

Electrical Substations have the following mission to accomplish:

- Step-up and step-down voltage transformation
- Connection of separate transmission and distribution lines into a system to increase efficiency and reliability of power supply
- Sectionalizing of power system to increase its reliability and operational flexibility – substation called “switching substation”

Let’s discuss the meaning of sectionalizing of power system, the reasons for it, and the benefits that it has using as an example power line connecting two substations shown in Fig.2.

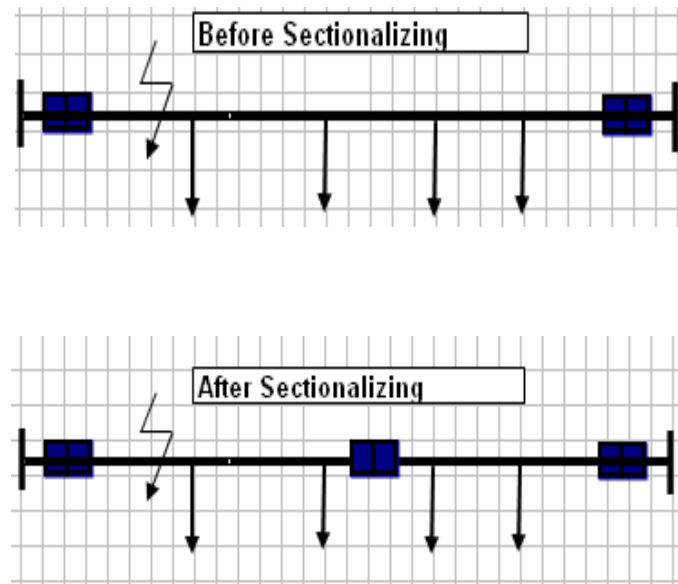

Fig.2. Sectionalizing of Power Systems.

As we can see, this line has circuit breakers on both ends and four taps feeding the customers (later we’ll talk about circuit breakers in a greater detail). Before sectionalizing, any fault on the line would lead to circuit breakers on both ends of the line opening (tripping) to isolate the fault. When it happens, all four customers will lose power supply. Let’s assume that we install another breaker in the middle of the line (see Fig.2 “After sectionalizing”); i.e. split the line in two sections or sectionalize it. If we do it, the same fault on the line will again lead to the opening of two adjacent breakers to isolate the fault: one installed in the beginning and one in the middle of the line. The

difference is that after the fault is isolated, one half of the line still remains in service feeding two out of four customers. So, by sectionalizing the line, we increased reliability of customer power supply.

Main Components of Substations

To fulfill their mission, substations include the following components:

- Power Transformers
- Circuit Breakers
- Disconnecting Switches
- Circuit Switchers
- Instrument Transformers
- Bus
- Relays and Instruments
- Auxiliary A.C. and D.C. Systems
- Overvoltage and Lightning Protection Systems
- Grounding System
- Remote Control and Operation Systems

Each of these components has its own tasks to accomplish, which we'll discuss in a greater detail in the next several sections of the course.

Power Transformers

Power transformers are needed to fulfill the main duty of substations: step-up and step-down voltage transformation. The following main components of transformers may be listed:

- Windings
- Core
- Tank
- Bushings
- Insulating medium (oil, gas)
- Cooling system (fans, pumps)

The different types of transformers may be distinguished based on following:

- Connections between the windings:
 - Transformers - Windings linked magnetically, isolated electrically
 - Autotransformers - Windings linked magnetically, connected electrically
- Number of windings:

- Two-winding transformers, for example 138/26 kV
- Three-winding transformers (every winding has a different voltage), for example, 138/26-13kV
- Transformers with a low voltage split windings (low voltage windings have the same voltage), for example: 138/13-13 kV

- Number of phases:
 - Single-phase
 - Three-phase

- Cooling class:
 - OA – liquid-immersed, self-cooled
 - OA/FA, OA/FA/FA - liquid-immersed, self-cooled/forced air cooled – has one or two sets of fans
 - OA/FA/FOA - liquid-immersed, self-cooled/forced air cooled/forced air – forced liquid cooled – has fans and oil pumps

The cooling options mentioned above are for power transformers using liquid insulation between their windings and transformer tank. Usually, the mineral oil is used for insulation and heat transfer from the windings. The higher the transformer load is, the higher the temperature of insulating oil will be. Because there is a maximum temperature for each type of insulating oil that can't be exceeded without oil losing its insulating abilities, there is a maximum transformer load that may be carried respectively. To increase transformer loading capabilities, the insulating oil should be cooled off to keep its temperature below the limit. This cooling is provided by the application of radiators, forced air cooling systems (fans) and forced liquid cooling systems (oil pumps). Each transformer may have several stages of cooling to allow for a gradual load increase. As an example, let's consider three-phase two-winding transformers shown in Fig. 3 and 4.



Fig. 3. 13/4 kV 6.0/9.0 MVA OA/FA Transformer



Fig. 4. 138/13 kV 27/36/45 MVA OA/FA/FA Transformer

13/4 kV transformer (see Fig. 3) has one set of cooling fans, as well as load ratings of 6.0 MVA without fans and 9.0 MVA with fans running. 138/13 kV transformer (see Fig. 4) has 2 sets of fans, as well as load ratings of 27 MVA without fans, 36 MVA with one set of fans and 45 MVA with two sets of fans running. Transformer fans are usually operated automatically through control schemes based on the use of oil temperature sensors.

Voltage Transformation Equation

The following relationship exists between transformer primary (V_P) and secondary (V_S) voltages and primary and secondary winding numbers of turns:

$$V_P / V_S = N_P / N_S$$

Where:

N_P = Primary winding number of turns

N_S = Secondary winding number of turns

Example:

230/13 kV single-phase step-down transformer has a primary winding with 300 turns. How many turns a secondary winding should have?

Solution:

$$230/13 = 300 / N_S \quad \Rightarrow \quad N_S = (300 \times 13) / 230 = 17$$

Circuit Breakers

The mission of circuit breakers is an interruption of load and rated short circuit current for circuit protection. They are widely used to sectionalize power systems (see Fig. 2). The main components of circuit breakers are:

- Interrupter
- Bushings
- Insulating medium (oil, gas)
- Bushing current transformers
- Operating mechanism

Circuit breakers may be designed for either outdoor or indoor installation. Examples of different circuit breakers are shown in Fig. 5 through 7.



Fig. 5. 230 kV Outdoor 2000 A Circuit Breaker



Fig. 6. 26 kV Outdoor 2000 A Circuit Breaker



Fig. 7. 26 kV Indoor Switchgear Draw-out Type 2000A Circuit Breaker

Disconnecting Switches

The mission of disconnecting switches is to isolate de-energized circuits. This is mostly required when we need to take either circuit or equipment (breaker, transformer, etc.) out of service for repair or maintenance and need to provide safe visible breaks on both sides of the de-energized element of the power system. What is important here is to remember that disconnecting switches cannot interrupt neither fault nor load current, and that is their major functional difference from the circuit breakers. However, because of these limited functions, disconnecting switches are much cheaper than circuit breakers.

The main components of disconnecting switches are:

- Post insulators
- Live parts
- Operating mechanism

The following types of disconnecting switches may be listed:

- Vertical break
- Double break
- Center break
- Side break
- Group operated (all 3 phases open simultaneously): Manually or motor operated
- Hook-stick switches (each phase open individually): Manually operated using the insulated stick

Examples of some of these switches are shown in Fig. 8 through 10.

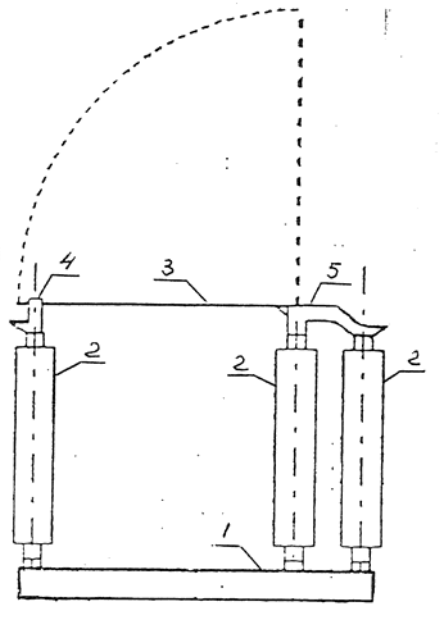

- 1 = Base
- 2 = Post Insulators
- 3 = Blade
- 4 = Jaw
- 5 = Hinge end

Fig. 8. Single Pole of Vertical Break Air Switch



Fig. 9a



Fig. 9b

Fig. 9. 230 kV 2000 A Double Break Disconnecting Switch
in Closed (a) and Open (b) Positions



Fig. 10. 4 kV Disconnecting Switch with Insulating Barriers between Phases

Circuit Switchers

So far, we've discussed two major substation switching devices: circuit breakers which can interrupt any load and rated fault current, as well as disconnecting switches which practically cannot interrupt any current. Very often, we need a switching device which is functionally located somewhere in between: it can interrupt any load and some fault current, and at the same time, can safely isolate the circuit. This device is called a circuit switcher. Its mission is to interrupt the load and rated short circuit current up to 20 kA. The main components of the circuit switchers are:

- Interrupter
- Isolating disconnecting switch
- Operating mechanism

An example of a typical circuit switcher is shown in Fig. 11. This device has the interrupting part of a circuit breaker and the isolating part of a disconnecting switch.



Fig.11. 230 kV 1200 A Circuit Switcher
Substation Bus Systems

All substation elements (transformers, breakers, disconnecting switches etc.) should be electrically connected in accordance with a planned substation arrangement. This connection is provided by substation bus system. There are the following main types of substation busses:

- Open air rigid bus
- Strain bus
- Gas insulated (GIS) bus
- Cable bus

Let's consider all these types and discuss what they consist of and what their strengths and weaknesses are.

1. Open Air Rigid Bus:

- Main components:
 - Supporting structures: frames, columns
 - Post insulators
 - Bare copper or aluminum conductor: tubular, busbar, cable
 - Connectors: bolted or welded
- Advantages:
 - Simplicity
 - More economical
 - Ease of trouble shooting
 - Short repair time
- Disadvantages:
 - Lower reliability
 - Exposure to weather, animal contact, etc.
 - Need for a large land area
 - Frequent maintenance

The examples of a typical open air rigid bus and connector used to assemble it are shown in Fig. 12 and 13, respectively.



Fig. 12. 138 kV Open Air Bus on Post Insulators



Fig. 13. Bolted Aluminum T-Conector 4”IPS Main to 4”IPS Tap

2. Strain Bus:

- Main components:
 - Supporting structures: towers, frames
 - Strain insulators with hardware
 - Flexible aluminum or ACSR (aluminum with a steel core) conductors
- Advantages:
 - Need for a smaller land area
 - Simplicity
 - More economical
 - Ease of trouble shooting
 - Short repair time
- Disadvantages:
 - Lower reliability
 - Exposure to weather, animal contact, etc.
 - Frequent maintenance

The examples of a typical strain bus and insulator assembly are shown in Fig. 14 and 15, respectively.



Fig. 14. 230 kV Strain Bus on Steel Towers



Fig. 15. 230 kV Strain Insulator Assembly

3. Gas Insulated Bus (GIB):

- Main components:
 - Center copper or aluminum conductor
 - Supporting insulators
 - Insulating gas (SF₆, air)
 - Metal enclosure
 - Bushings
 - External supporting structures

- Advantages:
 - Higher reliability
 - Protection from weather, animal contact, etc.
 - Need for a small land area
 - Low maintenance (especially for SF₆ bus)

- Disadvantages:
 - High cost
 - Inability to detect a gas leak (SF₆ bus)
 - Difficult troubleshooting
 - Long repair time

Example of 230 kV GIB termination is shown in Fig. 16.

4. Cable Bus:

- Main Components:
 - Cable (solid dielectric)
 - Terminators
 - Conduits or trays for installation
 - Supporting structures



Fig. 16. 230 kV Gas Insulated Bus

- Advantages:
 - Higher reliability
 - Protection from weather, animal contact, etc.
 - Need for a small land area
 - Low maintenance

- Disadvantages:
 - High cost
 - Difficult troubleshooting
 - Long repair time

The typical cable bus terminal is shown in Fig. 17.



Fig. 17. 138 kV Solid Dielectric Cable Bus Terminal

Instrument Transformers

To adequately operate power system, it is very important to measure its main electrical parameters (voltage, current, power, etc.) which is done by using voltmeters, ammeters, wattmeters, etc. All these typical instruments are designed for very low currents (usually up to 5 amperes) and voltages (usually up to several hundred volts). At the same time, real currents and voltages in power systems are measured in thousands of amperes and volts, respectively. Obviously, these values should be reduced to make them compatible with nominal values of common instruments, which may be done using instrument transformers whose mission is: accurate primary value (current and voltage) step-down transformation for relaying and metering circuits, as well as isolation between primary and secondary circuits (mostly for safety reasons).

The following standard secondary values are used for metering purposes:

- Currents: 1A or 5A
- Voltages: 115V or 120V phase-to-phase or phase-to-neutral

Depending on the arrangement of instrument transformers, the following types may be noted:

- Current transformers:
 - Free standing type (see Fig. 18)
 - Slip-on bushing type (see Fig. 19)
- Voltage transformers:
 - CCVT's (coupling capacitor voltage transformers) (see Fig. 20)
 - Potential transformers (see Fig. 21)



Fig. 18. Free Standing 138 kV 2000/5 A CTs



Fig. 19. 230 kV 2000/5 A Bushing CT



Fig. 20. 345 kV CCVT



Fig. 21. 26 kV Potential Transformers

Overvoltage Protection

One of the most common abnormal conditions in any power system are overvoltages which may take the form of surges from switching substation equipment and impulses from lightning strikes. Because these overvoltages may damage expensive elements of the power system (substation power transformers, transmission cables, etc.) an adequate overvoltage protection is installed to avoid it.

The main means of overvoltage protection are:

- Lightning arresters
- Protective gaps

The principle of operation of both arresters and protective gaps is based on diversion of overvoltage surges and impulses into the substation ground grid before they reach the protected equipment. The example of a typical surge surge arrester protecting a power transformer is shown in Fig. 22, where the surge arrester is the two-section porcelain column with a corona ring on the top.



Fig. 22. 230 kV Lightning Arrester

Equipment Installation Options

All substation equipment may be split in two groups: major and control. Let's define what kind of equipment belong to each of these groups and how they may be installed:

Major and Control Equipment Defined:

- Major equipment:
 - Power transformers
 - Switching equipment
 - Instrument Transformers
 - Overvoltage protection equipment

- Control equipment:
 - Relay protection systems
 - Metering systems
 - Auxiliary AC/DC Equipment
 - Alarm and remote control systems

Major and Control Equipment Installation Options:

- Major equipment :
 - Free standing
 - Switchgear
 - Unit substations (includes all substation components: transformer, switching equipment, etc. in one compact module)
 - Located in station control building
 -
- Control equipment:
 - Located in station control building
 - Unit substations
 - Switchgear

Examples of different equipment installation options are shown in Fig. 23 through 27.



Fig. 23. 26 kV Switchgear (Outside)



Fig 24. 4 kV Switchgear (Inside)



Fig. 25. 26/13 kV 9.0 MVA Unit Substation

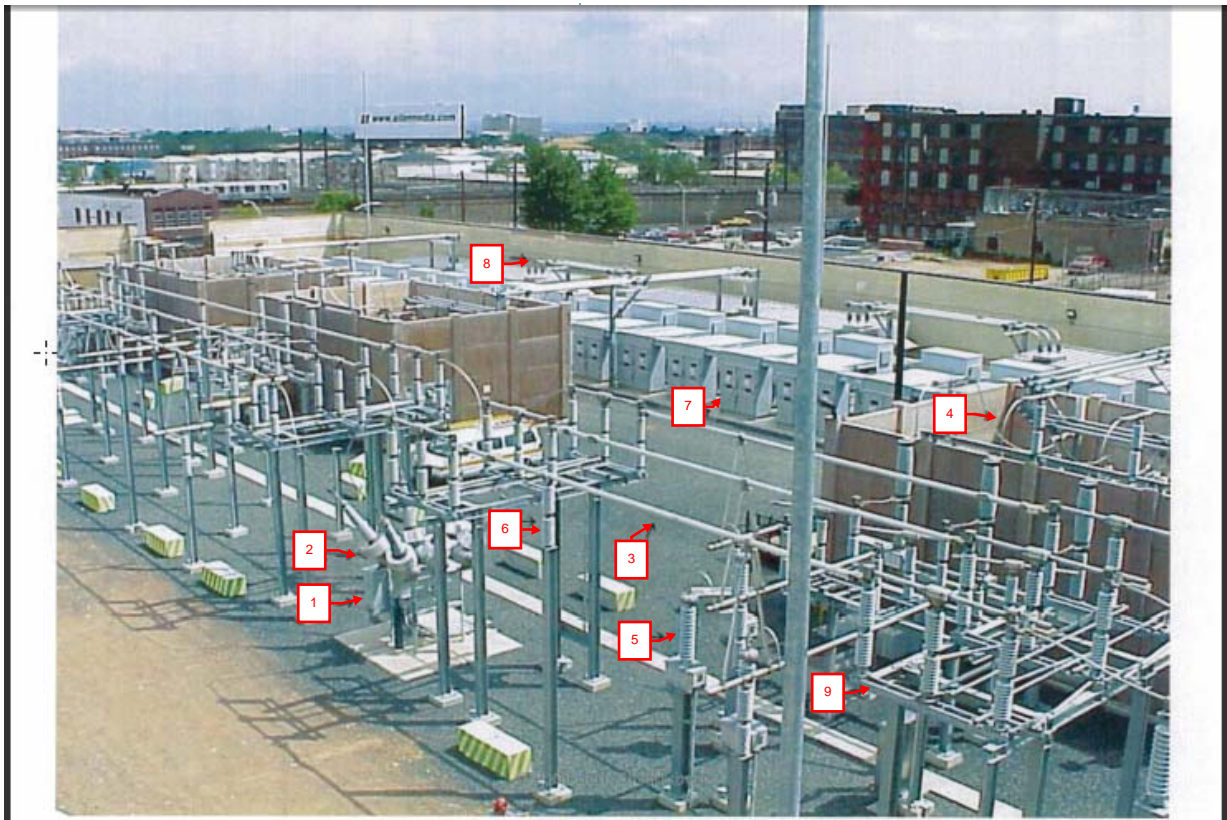

Fig. 27. 138/4 kV Substation, Including:

1 = 138 kV Circuit Breaker; 2 = 138 kV Bushing CTs; 3 = 138 kV Rigid Bus,
4 = 138/4 kV Transformer; 5 = 138 kV CCVT; 6 = 138 kV Post Insulator,
7 = 4 kV Switchgear; 8 = 4 kV Rigid Bus; 9 = 138 kV Disconnecting Switch

Conclusion

Part 1 of this course series provided an overview of modern electrical substations and their major components; concentrating on substation importance for reliable and effective operation of power systems to enable you to:

- Understand how power systems are arranged and what the transmission and distribution (T&D) system structure is.
- Identify the mission of substations and their place in the overall T&D structure.
- Understand what a substation consists of, and what each piece of a major equipment is for, including the following items:
 - Power Transformers
 - Switching Equipment
 - Substation Bus System
 - Instrument Transformers
 - Means of Overvoltage Protection
- Know the arrangement of each major equipment component and its installation options.